

Genesis Ceiling Horn-Strobe Installation Sheet

Description

The Genesis Ceiling Horn-Strobe is a fire alarm notification appliance designed for indoor ceilings and walls. See Table 1 for a list of model numbers.

Table 1: Models

Description	Number	
Horn-strobe, 15 to 95 multi-cd, white	ADTGC-HDVM	MGC-HDVM
	EGC-HDVM	XLSGC-HDVM
	GC-HDVM	ZGC-HDVM
Horn-strobe, 15 to 95 multi-cd, white, with FIRE marking	ADTGC-F-HDVM	MGC-F-HDVM
	EGC-F-HDVM	XLSGC-F-HDVM
	GCF-HDVM	ZGCF-HDVM
Horn-strobe, 15 to 95 multi-cd, red, with FIRE marking	EGCFR-HDVM	
	GCFR-HDVM	
	MGCFR-HDVM	

Field configurable jumper options are available for selecting the desired dB output, temporal or steady horn output, and strobe signal output.

The horn-strobe includes a field configurable switch for selecting the desired candela output. The candela output setting is locked in place and remains visible after final installation.

This strobe features an enhanced synchronization circuit to comply with the latest requirements of UL 1971 *Signaling Devices for the Hearing Impaired* and the latest Canadian standard CAN/ULC-S526. Synchronized operation requires a separately installed synchronization control module. See Table 2 for a list of compatible synchronization modules.

Install this device in accordance with applicable requirements in the latest editions of the NFPA codes and standards and *Canadian Electrical Code, Part 1, Section 32* and *CAN/ULC-S524, Standard for the Installation of Fire Alarm Systems*, and in accordance with the local authorities having jurisdiction.

Table 2: Compatible synchronization module models

Description	Number	
Auto-sync output module	SIGA-CC1S	SIGA-MCC1S
	GSA-CC1S	GSA-MCC1S
Genesis signal master - remote mount	ADTG1M-RM	MG1M-RM
	EG1M-RM	XLSG1M-RM
	G1M-RM	ZG1M-RM

Installation

WARNING: To reduce the risk of shock, disconnect all power and allow 10 minutes for stored energy to dissipate before handling.

Caution: Electrical supervision requires the wire run to be broken at each terminal. Do not loop the signaling circuit field wires around the terminals.

To install the horn-strobe:

1. Remove the cover by depressing the tab on the side of the unit with a small screwdriver. Turn the cover counterclockwise to release.
2. Set the horn signal, sound output level, and strobe signal to the desired settings. See Figure 2.
3. Connect the strobe terminals to the signal circuit field wiring. You must observe polarity for the unit to function properly. See Figure 4.
4. Slide the candela switch to the desired candela output (95, 115, 150, or 177 cd) by aligning it with the indicator below the switch. See Figure 1.
5. Mount the unit onto a compatible electrical box. See Figure 5.
6. Replace the cover by positioning the alignment arrows together and rotating the cover clockwise.
7. Test the unit for proper operation.

Figure 1: Candela switch

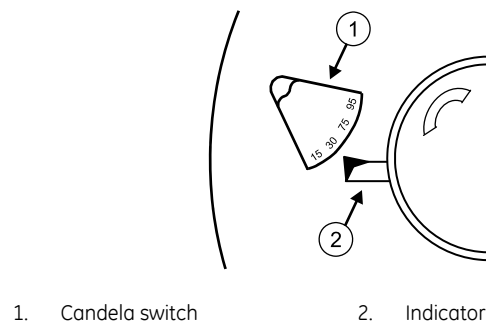
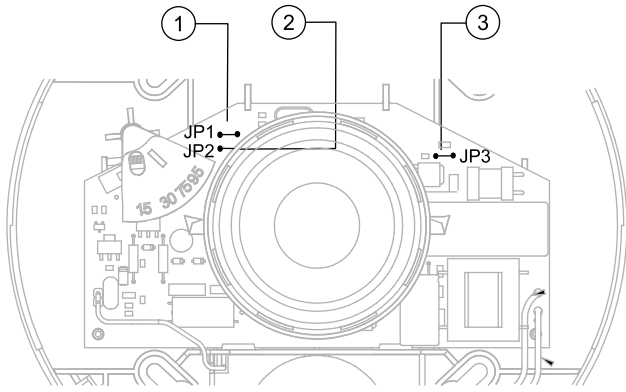

Figure 2: Horn and strobe settings



1. JP1: Horn signal jumper: Cut to change from temporal to steady
2. JP2: Strobe signal output: Cut to change from 1 flash per second (public mode) to temporal (private mode)
3. JP3: Horn sound output: Cut to change from high dB to low dB

Note: If the strobe is set to temporal (private mode), this device is no longer UL 1971 or ULC-S526 Listed or FM Approved but is UL 1638 Listed.

Figure 3: UL 1971 minimum light output (% of rating vs. angle)

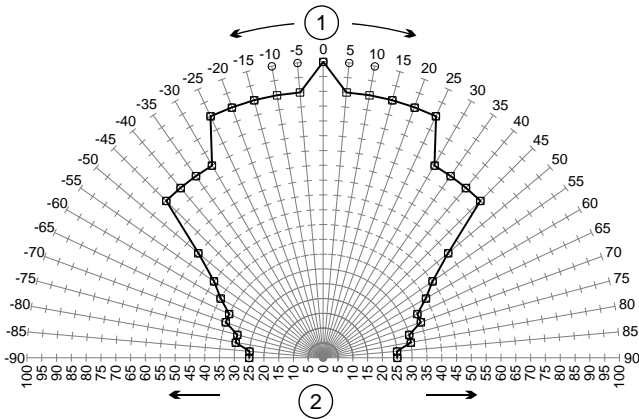

1. Angle
 2. Percentage of rated output
- Note: Horizontal and vertical outputs have the same pattern

Wiring

Figure 4: Wiring Diagram

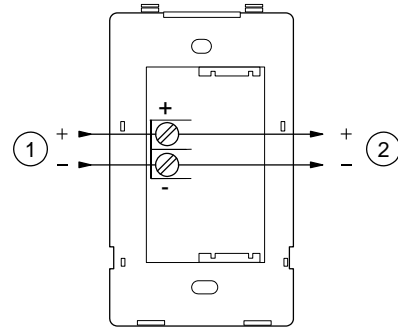

1. From NAC output
 2. To next NAC output
- Note: Signal polarity is shown in the alarm condition.

Figure 5: Mounting diagram

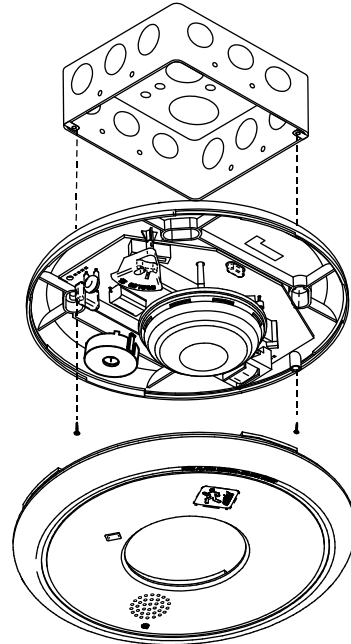

Table 3: Strobe operating current in RMS (A)

	15 cd	30 cd	75 cd	95 cd
VDC	0.147	0.190	0.316	0.372
VFWR	0.189	0.253	0.417	0.451

VDC = Volts direct current, regulated and filtered
 VFWR = Volts full wave rectified

Operating currents shown above were measured by UL at 16 VDC and 16 VFWR.

Table 4: Sound level output (dBA)

Signal	VDC	High db	Low db
Temporal	16	79.8	75.0
	24	83.3	78.0
	33	85.0	80.9
Steady	16	83.2	79.3
	24	85.4	83.0
	33	87.8	85.9

UL464: Sound level output at 10 ft. (3.05 m) measured in a reverberant room

Table 5: Minimum sound level output per ULC-S525 (dBA, peak)

Signal	Voltage	High db	Low db
Temporal	Reg. 24 VDC	91	89
	Reg. 24 VFWR	96	93
Steady	Reg. 24 VDC	93	89
	Reg. 24 VFWR	96	93

ULC-S525: Meets or exceeds 85 dBA in an anechoic chamber at 10 ft. (3.05 m).

Table 6: Audible directional characteristics (horizontal pattern)

Angle (°) [1]	Sound output (dBA) [2]
90 (Ref)	0 (Ref)
75 and 115	-3
70 and 120	-6

[1] Angles are measured from a perpendicular axis; positive angles to the right.

[2] Peak output at regulated 24 VDC, set for temporal tone.

Table 7: Audible directional characteristics (vertical pattern)

Angle (°) [1]	Sound output (dBA) [2]
90 (Ref)	0 (Ref)
65 and 135	-3
55 and 140	-6

[1] Angles are measured from a perpendicular axis; positive angles are up.

[2] Peak output at regulated 24 VDC, set for temporal tone.

Figure 6: Light output profile

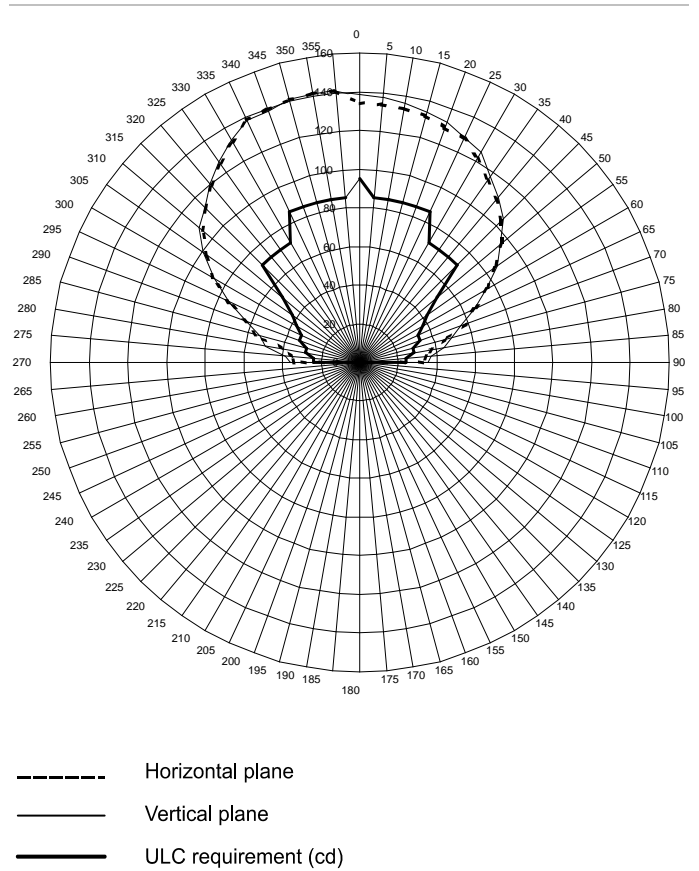

----- Horizontal plane
 _____ Vertical plane
 _____ ULC requirement (cd)

Maintenance

This unit is not serviceable or repairable. Should the unit fail to operate, contact the supplier for replacement.

Perform a visual inspection and an operational test twice a year or as directed by the local authority having jurisdiction.

Do not change the factory-applied finish.

Specifications

Voltage	Regulated 24 VDC, 24 VFWR
Strobe operating current	See Table 3
Light output	Selectable at 15, 30, 75, and 95 cd
Sound level output	See
Default settings	
Signal	Temporal
Sound level output	High dB
Strobe signal output	1 flash per second (fps)
Wire size	12 to 18 AWG (0.75 TO 2.50 mm ²)
Compatible electrical boxes	North American 4 in. square electrical box, 2-1/8 in. deep (no extension ring)
Operating environment	
Temperature	32 to 120°F (0 to 49°C)
Relative humidity	0 to 93% noncondensing

Regulatory information

Manufacturer	GE Security, Inc., 8985 Town Center Parkway, Bradenton, FL 34202, USA
Year of manufacture	The first two digits of the DATE MFG number (located on the product identification label) are the year of manufacture
UL/ULC rating	Regulated 24 DC and 24 FWR This device was tested to the regulated 24 DC/FWR operating voltage limits of 16 V and 33 V. Do not apply 80% and 110% of these values for system operation.
Environmental class	UL: Indoor
Synchronization	Meets UL 1971 requirements. Maximum allowed resistance between any two devices is 20 Ω . Refer to specifications for the synchronization control module, this strobe, and the control panel to determine allowed wire resistance.
Agency listings	Meets ULC-S525, ULC-S526 UL 464. UL 1638 and UL 1971